

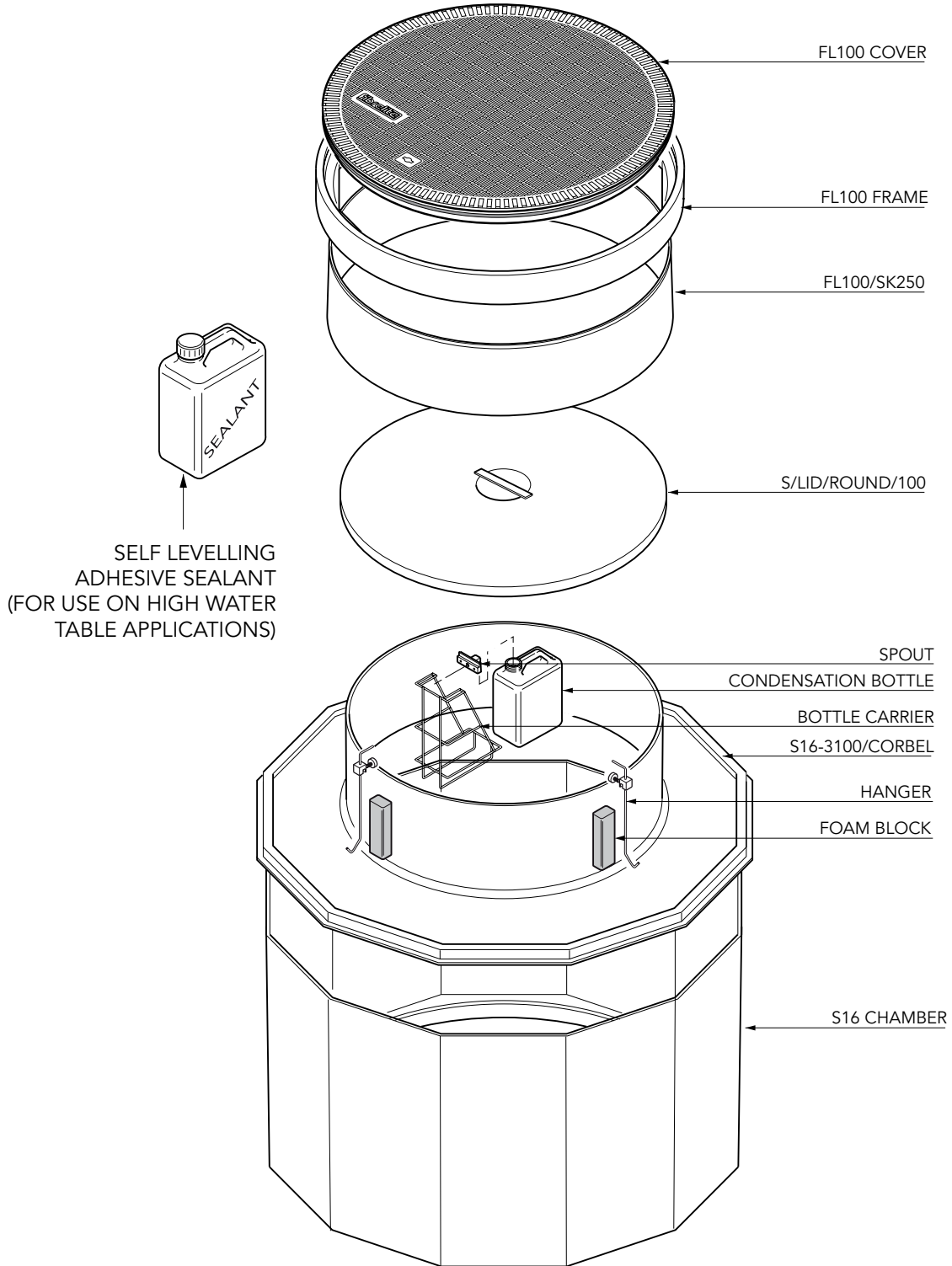

<b>Notes:</b>	Category: <b>HEIGHT ADJUSTABLE ROUND SUMP SYSTEMS</b>		 <b>FIBRELITE</b>
	Product Description: 1.5m diameter 12 sided sump with reverse flange, corbel, adjustable height skirt, internal lid, and round 1020mm flat sealed cover and frame		
For reference purposes only. This drawing is not a specification.	Drawing No.: <b>1</b>	Product Code: <b>S16-3100/SEAL</b>	
	Date: <b>Nov 2008</b>	Revisions:	



<b>Notes:</b>	Category: <b>HEIGHT ADJUSTABLE ROUND SUMP SYSTEMS</b>		 <b>FIBRELITE</b>
	Product Description: 1.5m diameter 12 sided sump with reverse flange, corbel, adjustable height skirt, internal lid, and round 1020mm flat sealed cover and frame		
For reference purposes only. This drawing is not a specification.	Drawing No.: <b>2</b>	Product Code: <b>S16-3100/SEAL</b>	
	Date: <b>Nov 2008</b>	Revisions:	



**VERY IMPORTANT**  
 OUTER EDGE "A" OF FRAME SET 5 - 10MM  
 ABOVE GENERAL FORECOURT AREA WITH  
 CONCRETE RAMPED AWAY OVER 300MM.

**TYPICAL INSTALLATION**

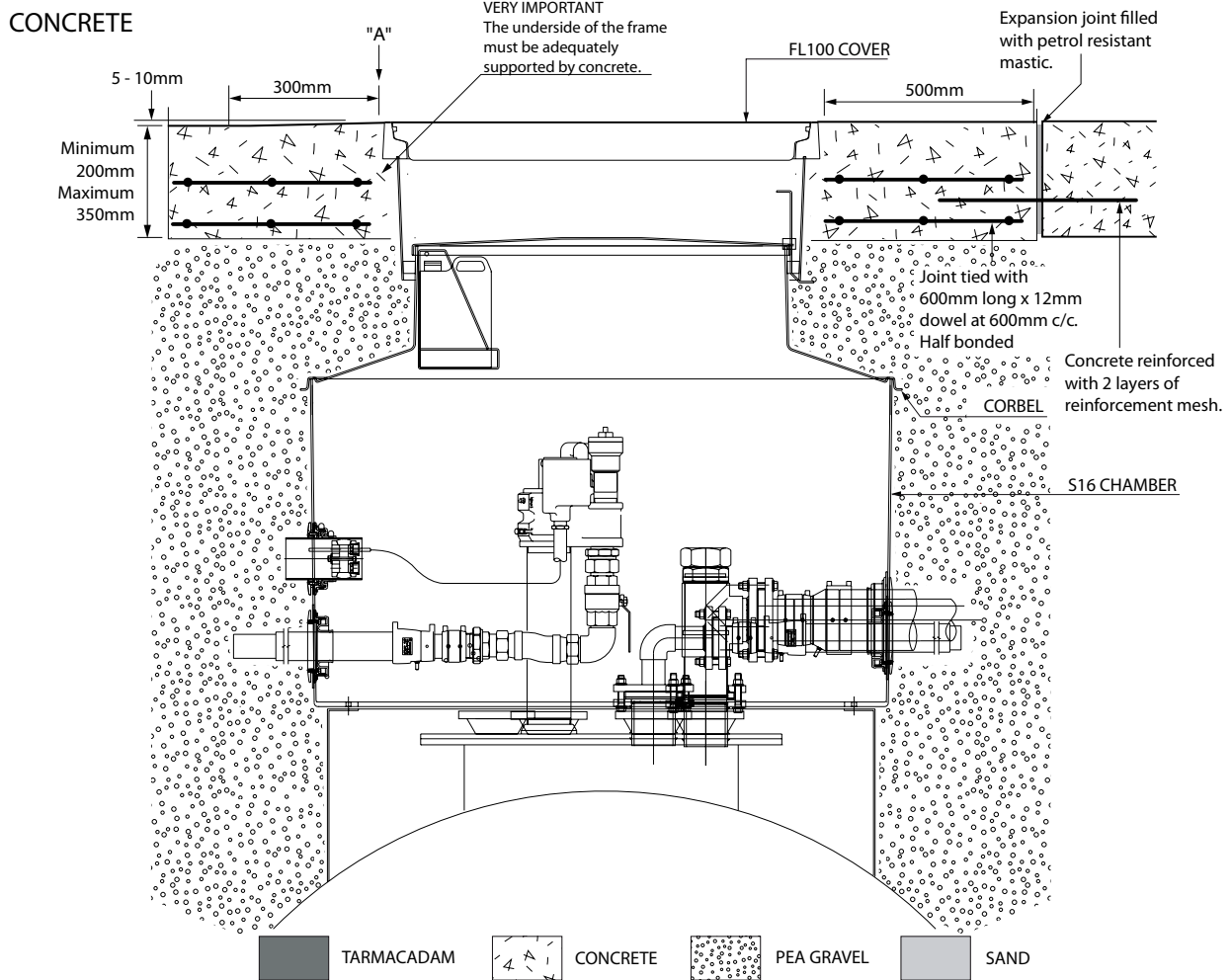

**ALTERNATIVE INSTALLATION ADVICE**

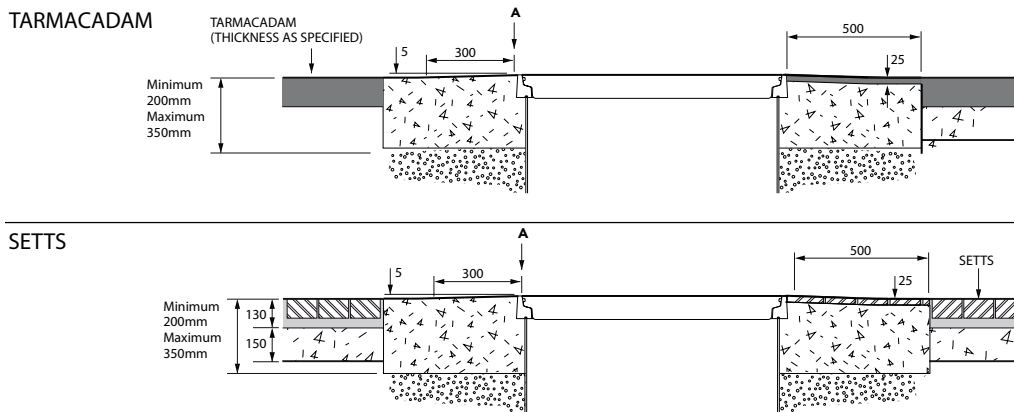

**Notes:**

Category: **HEIGHT ADJUSTABLE ROUND SUMP SYSTEMS**

Product Description: 1.5m diameter 12 sided sump with reverse flange, corbel, adjustable height skirt, internal lid, and round 1020mm flat sealed cover and frame

For reference purposes only.  
 This drawing is not a specification.

Drawing No.: **3**

Product Code: **S16-3100/SEAL**

Date: **Nov 2008**

Revisions:





BILL OF MATERIALS ON FOLLOWING PAGE

NOTE: SEALANT BETWEEN SKIRT AND CORBEL ONLY TO BE USED ON HIGH WATER TABLE APPLICATION

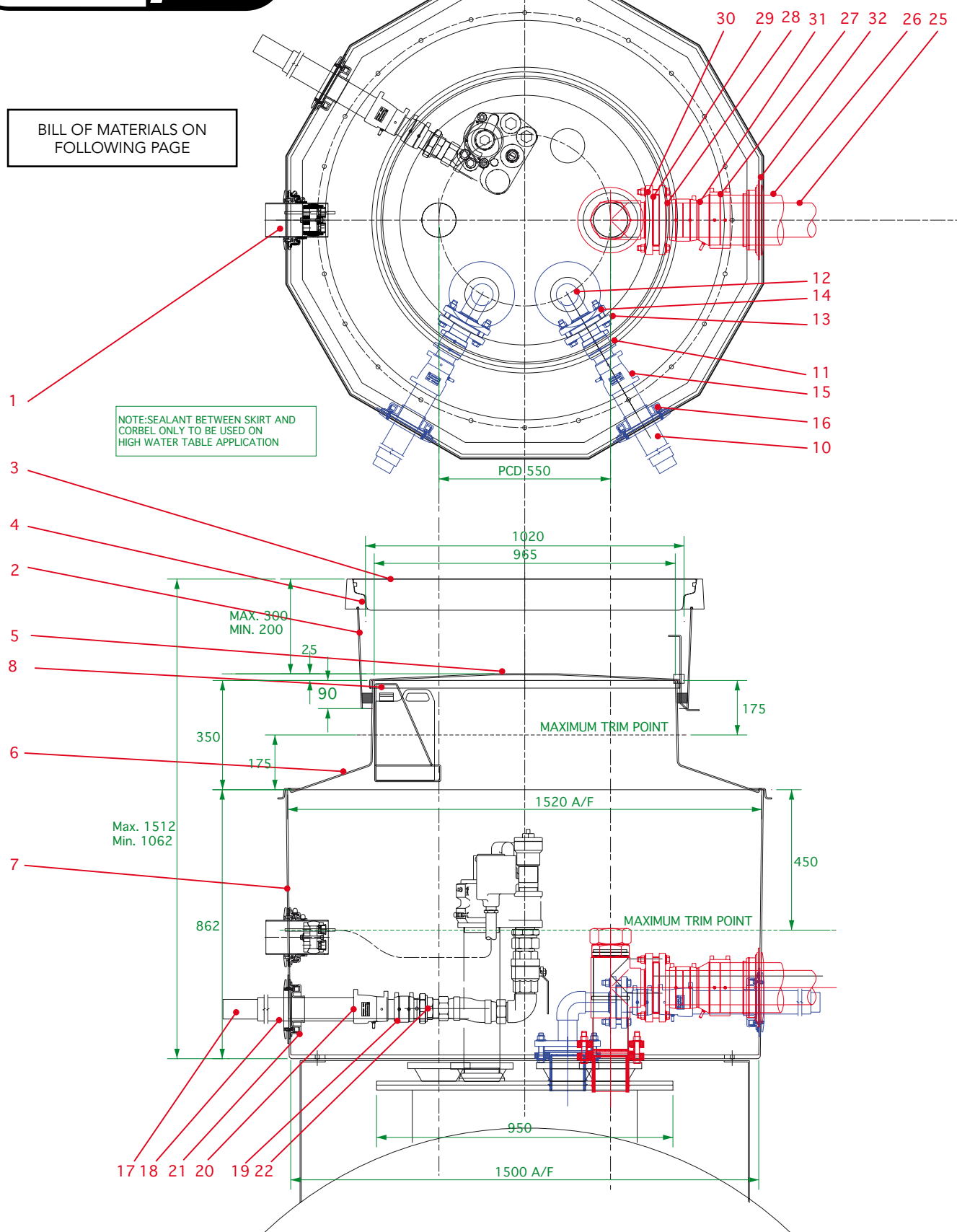

<b>Notes:</b>	<b>Category: HEIGHT ADJUSTABLE ROUND SUMP SYSTEMS</b>		
	<b>Product Description:</b> 1.5m diameter 12 sided sump with reverse flange, corbel, adjustable height skirt, internal lid, and round 1020mm flat sealed cover and frame		
For reference purposes only. This drawing is not a specification.	<b>Drawing No.:</b> 4	<b>Product Code:</b> S16-3100/SEAL	
	<b>Date:</b> Nov 2008	<b>Revisions:</b>	



	ITEM	Code Number	QTY
1	Cable Entry Seal Kit	PCE/1/KIT	1
2	Skirt	FL100/SK250	1
3	1000mm Flat Sealed Cover	FL100	1
4	Frame	FL100 Frame	1
5	Internal Lid - Structural	S/LID/ROUND/100	1
6	Corbel	S16-3100/Corbel	1
7	S16 Sump	S16	2
8	Corbel Skirt Seal	S/CS/SEALANT & S/CS/BOTTLE	1 each
<b>75/63mm Vent - Mechanical Tank Sump Entry</b>			
10	Pipe UPP Coaxial 63mm	001-075-063-xxx	2
11	Welding Socket	02.63	2
12	Stub UPP 63mm	05.63	2
13	Flange Circular DN50 UPP 63mm	06.63	2
14	Gasket UPP 63mm for Stub	07.63	2
15	SC Welding Reducer 75/63mm	49.075.063.TP1	2
16	Fibrelite 75mm Pipe Kit Seal	PSB/75	2
<b>75/63mm Product - Mechanical Tank Sump Entry</b>			
17	Pipe UPP Extra 63mm	001-075-063-XXX	1
18	Pipe UPP Extra SC 75mm	001-075-063-XXX	1
19	Welding Socket UPP 63mm	02.63	1
20	SC Welding Reducer 75/63mm + TP	49.075.063.TP1	1
21	Fibrelite 75mm Pipe Seal Kit	PSB/75	1
22	2" Union Adaptor BSPT	82.063.UF BSPT	1
<b>160/110mm Fill - Mechanical Tank Sump Entry</b>			
25	Pipe UPP Extra 110mm	001-110-006-FILL	1
26	Pipe UPP Secondary 160mm	000-160-006-SC	1
27	Welding Socket UPP 160mm SC	02.160(SC)	1
28	Stub 110mm	05.110	1
29	Flange Circular DN100 UPP 110mm	06.110	1
30	Gasket UPP 110mm for Stub	07.110	1
31	Reducer UPP 160/110mm + Test Port	13.160.110.TP	1
32	Fibrelite 160mm Pipe Seal Kit	PSB/160	1

**Notes:**

Category: **HEIGHT ADJUSTABLE ROUND SUMP SYSTEMS**

Product Description: 1.5m diameter 12 sided sump with reverse flange, corbel, adjustable height skirt, internal lid, and round 1020mm flat sealed cover and frame

For reference purposes only.  
This drawing is not a specification.

Drawing No.: **5**

Product Code: **S16-3100/SEAL**

Date: **Nov 2008**

Revisions:

